

# TRAFFIC & INDUSTRIAL SAFETY MIRRORS



## RED AND WHITE FRAME

### PRODUCT CODE

Anti frost / Anti condensation ▶ Code 846AB



### TECHNICAL SPECIFICATION

- > Optic: anti-frost and anti-condensation  
Mirror size: Ø 600 mm
- > Frame: white with red reflectors
- > Packaging dimensions: 1010 x 200 x 1010 mm
- > Gross weight: 20.0 kg
- > Angle of convexity: for a field of vision of approximately 90° used at junctions where users are coming from 2 different directions
- > Maximum viewing distance between the mirror and viewer: approx 11 m
- > Fixing kit supplied
- > Full guarantee (mirror, frame and fixings)\*
- > Manufactured in France
- > 100% recyclable

### DIMENSION

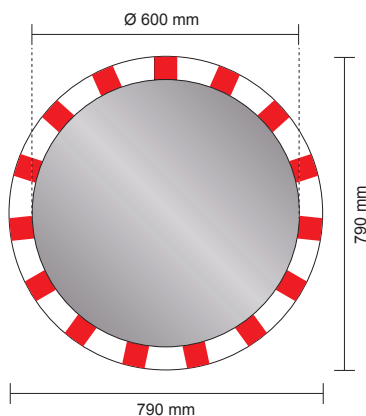

### GUARANTEE



- > Unbreakable > UV inhibited > Heat accumulator system, demisting & de-icing with no electrical power
- > 6 year guarantee



### FIXING KIT DIAGRAM

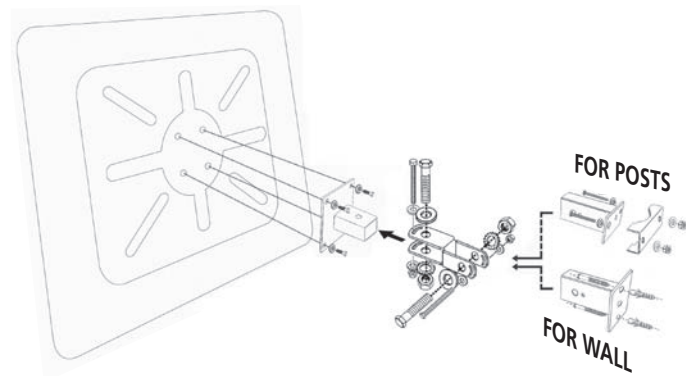

All mirrors are supplied complete with bolts and brackets kit in stainless steel, adaptable for walls and round posts (Ø 76 to 90 mm) or rectangular (60x80 or 80x80mm).

If mirrors are post mounted, only steel posts are to be used.

### RECOMMENDED INSTALLATION

