

# TRAFFIC & INDUSTRIAL SAFETY MIRRORS



## WITH RED & WHITE FRAME

### PRODUCT CODE

Anti frost / Anti condensation ▶ Code 858AB



### GUARANTEE



> Unbreakable > UV inhibited > Heat accumulator system, demisting & de-icing with no electrical power  
> 6 year guarantee



### TECHNICAL SPECIFICATION

- > Optic: anti-frost and anti-condensation -  
Mirror Size: 800x600 mm
- > Frame: white with red reflectors
- > Packaging dimensions : 1300x200x970 mm
- > Gross weight: 25.0 kg
- > Angle of convexity: for a field of vision of approximately 90° used at junctions where users are coming from 2 different directions
- > Maximum viewing distance between the mirror and viewer: approx 20 m
- > Fixing kit supplied
- > Full guarantee (mirror, frame and fixings)\*
- > Manufactured in France
- > 100% recyclable

### FIXATION KIT DIAGRAM

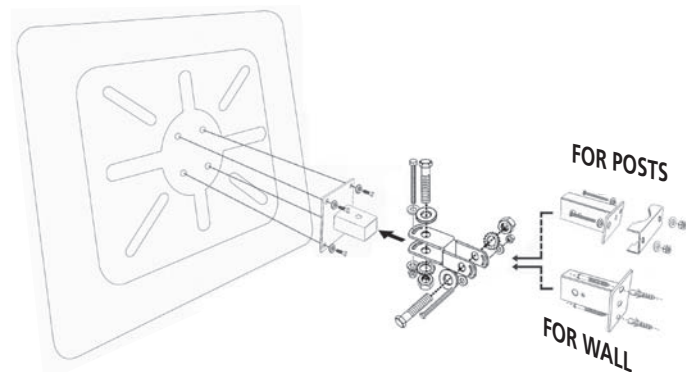

All mirrors are supplied complete with bolts and brackets kit in galvanised steel, adaptable for walls and round posts (Ø 76 to 90 mm) or rectangular (60x80 or 80x80mm).

If mirrors are post mounted, only steel posts are to be used.

### DIMENSIONS

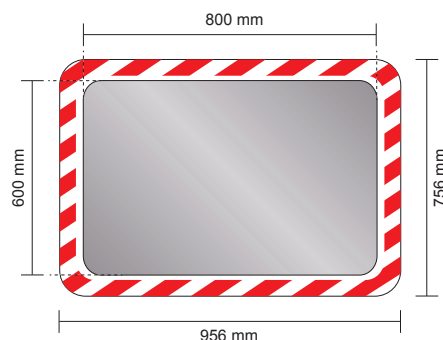

### RECOMMENDED INSTALLATION

